

Turn Signal and Hazard Warning Light (w/ Daytime Running Light)

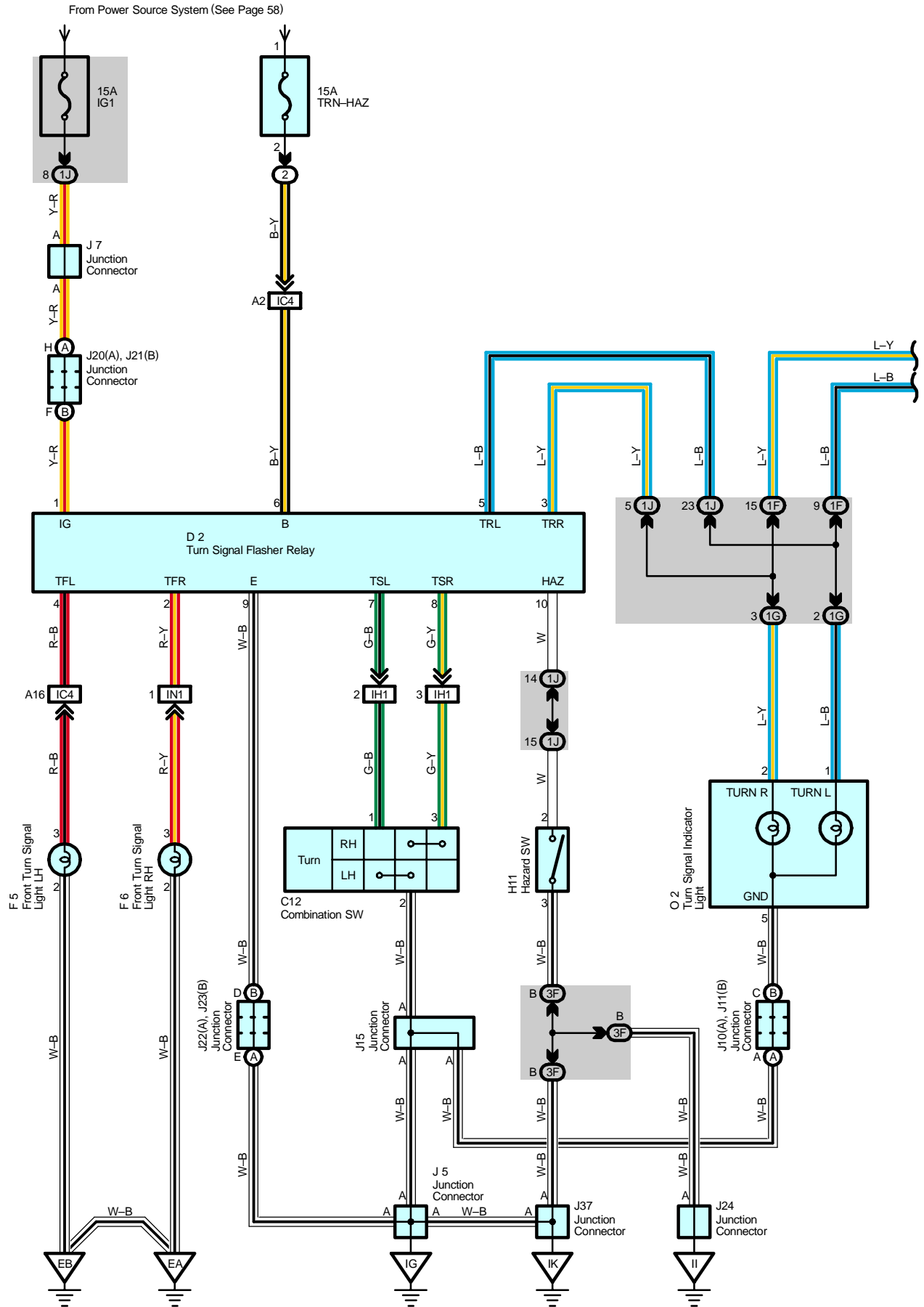

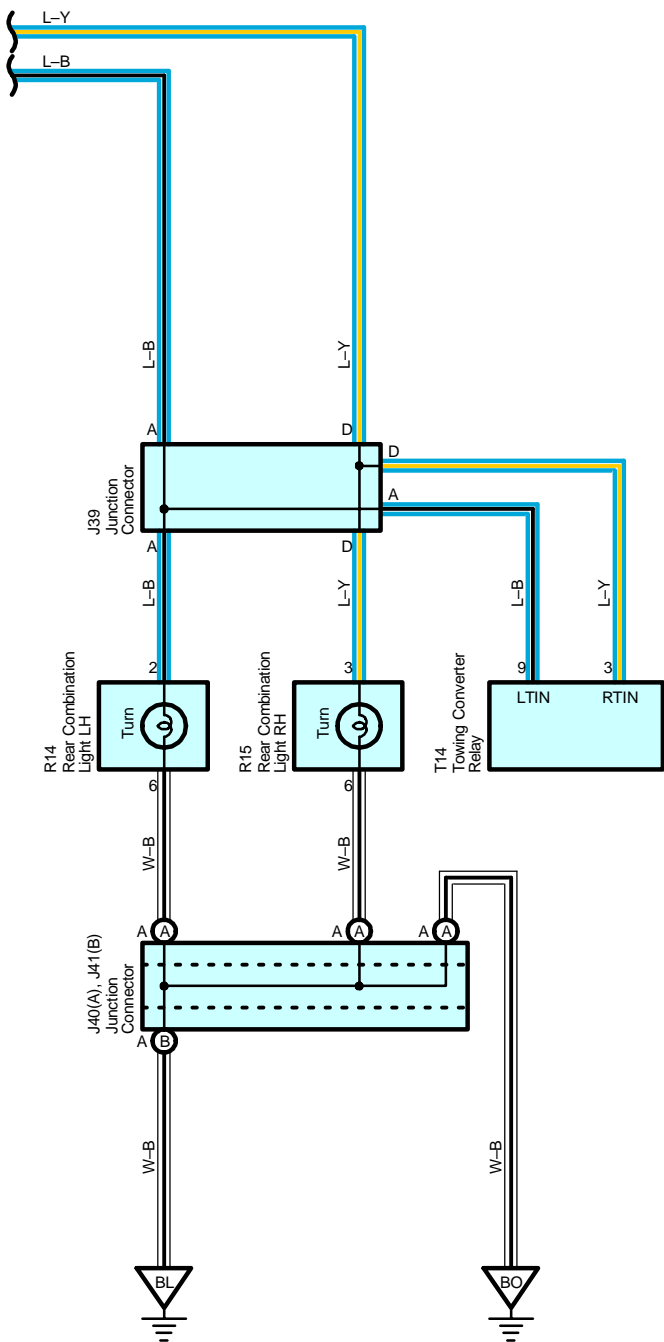

Turn Signal and Hazard Warning Light (w/ Daytime Running Light)

Service Hints

D2 Turn Signal Flasher Relay

1-Ground : Approx. 12 volts with the ignition SW at ON position

9-Ground : Always continuity

6-Ground : Always approx. 12 volts

○ : Parts Location

Code	See Page	Code	See Page	Code	See Page
C12	37	J10	A 38	J39	40
D2	37	J11	B 38	J40	A 40
F5	32 (2UZ-FE)	J15	38	J41	B 40
	34 (1GR-FE)			O2	39
F6	32 (2UZ-FE)	J20	A 38	R14	41
	34 (1GR-FE)	J21	B 38	R15	41
H11	37	J22	A 38	T14	41
J5	38	J23	B 38		
J7	38	J24	38		
		J37	38		

○ : Relay Blocks

Code	See Page	Relay Blocks (Relay Block Location)
2	22	Engine Room R/B (Engine Compartment Left)

○ : Junction Block and Wire Harness Connector

Code	See Page	Junction Block and Wire Harness (Connector Location)
1F	24	Floor No.2 Wire and Driver Side J/B (Lower Finish Panel)
1G	25	Instrument Panel Wire and Driver Side J/B (Lower Finish Panel)
1J		
3F	28	Instrument Panel Wire and Center J/B (Instrument Panel Brace RH)

□ : Connector Joining Wire Harness and Wire Harness

Code	See Page	Joining Wire Harness and Wire Harness (Connector Location)
IC4	48	Instrument Panel Wire and Engine Room Main Wire (Left Kick Panel)
IH1	50	Instrument Panel Wire and Instrument Panel Wire (Behind the Combination Meter)
IN1	52	Instrument Panel Wire and Engine Room Main Wire (Right Kick Panel)

▽ : Ground Points

Code	See Page	Ground Points Location
EA	44 (2UZ-FE)	Front Right Fender
	46 (1GR-FE)	
EB	44 (2UZ-FE)	Front Left Fender
	46 (1GR-FE)	
IG	48	Left Kick Panel
II	48	Instrument Panel Brace RH
IK	48	Right Kick Panel
BL	54	Floor Seat Crossmember LH
BO	54	Rear Pillar LH

